

6 位数按键设定式计数器

6 DIGIT KEYBOARD PRESET COUNTER

产品规格 Specification

型号规格 Item No	TC - 63KA
显示范围 Display Range	- 99999 ~ 999999
设定范围 Setting Range	1 ~ 999999
显示尺寸 Display Height	Count LED 0.56" (RED)
计数输入 Input Signal Mode	有接点输入 Contact Input:25HZ 无接点输入 NO Contact Input:1kHz
输出方式 Output System	Relay Output (AC 250V/3A)
输出时间 Output Hold Time	0.1 ~ 9.9 Seconds (Variable)
复归方式 Reset System	External, Manual, AutoReset
输入信号 Input Level	NPN, Open Collector
停电记忆 Power Failure Memory	EEPROM Memory Keep Ten Years
信号电源 DC Out For Sensor	12V DC ±5 % Max Electric Current Capacity 100Ma
电源电压 Power Supply	AC 110V/220V ±15 % 50Hz/60Hz
消耗功率 Power Consumption	5.5 VA
耐温湿度 Operating Temperature Humidity	- 10°C ~ +50°C 35 % ~ 85 % RH
外形尺寸 External Dimensions	96mm × 48mm × 123mm (盘面开孔 Mounting Flush Dimension:92mm × 45mm)

面板说明 Panel Explanation

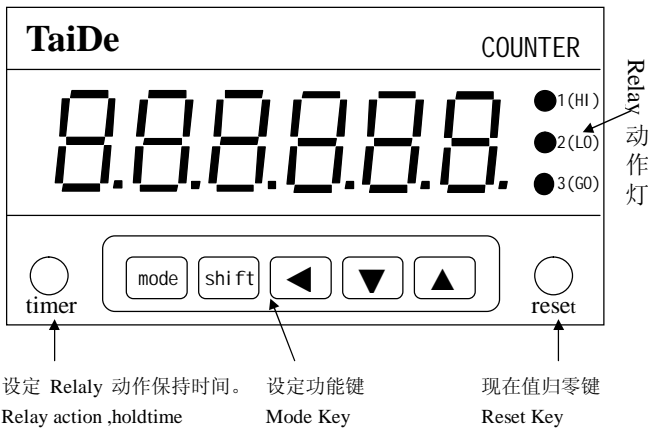

Mode 键 选择设定功能类别

- (1) P5-1: 设定第一段目标值, 范围 1 ~ 999999.
- (2) P5-2: 设定第二段目标值, 范围 1 ~ 999999.
- (3) P5-3: 设定第三段目标值, 范围 1 ~ 999999.
- (4) SCL: 倍率设定, 范围 0.0001 ~ 99.9999.
- (5) P0nt: 小数点位置设定.

Used to change display mode or operation mode

- (1) P5-1: Set first preset value, range 1 ~ 999999.
- (2) P5-2: Set two preset value, range 1 ~ 999999.
- (3) P5-3: Set three preset value, range 1 ~ 999999.
- (4) SCL: Percentage setup, range 0.0001 ~ 99.9999.
- (5) P0nt: Decimal point setup.

Shift 键 Shift Key

决定设定类别或结束设定。

Used to change display mode or operation mode, and when the function setups over, please press this key

◀ 键: 设定位数左移。

Move left to select the setting option.

▲ 键: 位数值加 1, 按住不放则连续递增。

The preset value add one, pressing the pushbutton, the preset value go on adding to reaches the desired value.

▼ 键: 位数值减 1, 按住不放则连续递减。

The preset value dec one, pressing the pushbutton, the preset value go on decing to reaches the desired value.

timer 键 timer Key

设定 Relay 动作保持时间 范围 0.1 ~ 9.9sec
Set Relay action, holdtime, range 0.1 ~ 9.9sec

reset 键 reset Key

在按下此键时, 现在值清除为零。

Press the key to clear the current displayed value.

外形尺寸图 Dimension Diagram (Unit: mm)

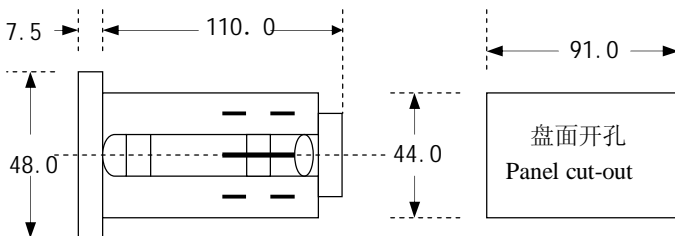

端子说明 Connection Diagram

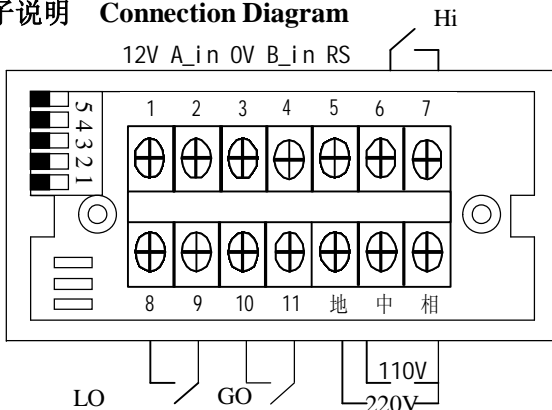

设定流程 Preset Step

设定类别 Setup type	步骤 step
PS-1	mode → shift → ◀ → ▶ → ▼ PS-1 → 654321 → 设定第一段值 Start to set the first value.
PS-2	mode mode shift PS-1 → PS-2 → 654321 → 设定第二段值 Start to set the two value.
PS-3	mode mode shift PS-1 → --- → PS-3 → 654321 → 设定第三段值 Start to set the three value.
SCL	mode shift PS-1 → --- → SCL → 01.0000 设定倍率 Start to set percentage
Port	mode PS-1 → --- → Port 用 ◀ 决定小数点的位置 Press ◀ to select the decimal point

信号输入方式 Signal Input Type

端子 A_in (2 脚), B_in (4 脚), RS (5 脚) 输入方式皆为 NPN 输入 (无电压入力)
The signal input way of the terminal A_in (2 pin), B_in (4 pin), and RS (5 pin) all are "NPN" input.

SW1-1: 输入频率开关 SW1-1 Switch

1: SW1-1 为 OFF 时, 信号无滤波电容, 频率可达 1KHz.

When SW1-1 is "OFF", Removes damping capacitor and allows operation up to 1KHz.

2: SW1-1 为 ON 时, 信号有滤波电容, 频率可达 25Hz.

When SW1-1 is "ON", Connects small damping capacitor and limits counter frequency to 25Hz.

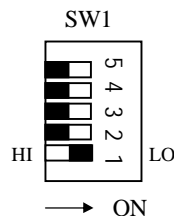

SW1-5: 开关 SW1-5: Switch

Sw1-5 ON 时, 无法选择设定功能, Sw1-5 OFF 时方可选择设定功能, 在设定功能完成后, 尽量保持 Sw1-5 在 ON 的位置, 以免人为操作失误.

When Sw1-5 is ON, the function can't be set. Just as Sw1-5 OFF, then the function can be selected. When the function mode is selected, trying to hold Sw1-5 in the "ON" condition to keep from man-made mistakes.

SW1-3, SW1-4: 开关 SW1-3, SW1-4: Switch

Relay 复归 N.R.C. Relay return N.R.C

1: N: 手动 (MANUAL) SW1-3 OFF, SW1-4 OFF.

计数值等于设定值时 Relay ON, 计数值继续上数, 直到手动或外部复归时, Relay 才复归, 值归零。
When the counting value is equal to the preset value, the relay will turn on. The counter will keep counting up until we press down the "reset" button or connects the terminal 3 & 5 together at the same time, then the display value will return to zero.

2: R: 回归 (RETURN) SW1-3 ON, SW1-4 OFF.

计数值等于设定值时 Relay ON, 计数值继续上数, 待到时间 (由 timer 键设定) 后 Relay 复归, 值归零。
When the counting value is equal to the preset value, the relay will turn on. The counter will keep counting up, but after several seconds, the relay returns to the original condition and the display value will return to zero.

3: C: 继续 (CONTINUE) SW1-3 OFF, SW1-4 ON.

计数值等于设定值时 Relay ON, 计数值立即归零后继续上数, 而 Relay 到时间 (由 timer 键设定) 后复归。
When the counting value is equal to the preset value, the relay will turn on and the display returns to zero. then the counter will keep on counting, and the relay will return to the original condition after several seconds.

SW1-2: 开关 SW1-2: Switch

计数方式 (Counting Method)

1: Sw1-2 OFF: 单相加算, 单相减算 (单相入力)

Sw1-2 OFF: single addition, single dection (single phase)

2: Sw1-2 ON: 加减算 (90° 相位差输入)

Sw1-2 ON: addition and subtraction (Quadrature input)
此计数模式常配合译码器 (encoder) 使用, 或配合两个 sensor, 但要注意相位差尽量为 90°。

This quadrature counting mode can be implemented by the rotary encoder or two sets of photoelectric sensors.

3: 注意在改变计数模式后, 必须切断电源再重新通电开机。

You must turn on the counter again when change the mode of the counter

